

ASYMTEK Quantum Q-6800 Series

Automated Fluid Dispensing System with Advanced Process Controls

Features and Benefits

- Large dispense area (423 x 458 mm) ideal for dual-valve dispensing and a wide-range of substrate sizes
- Range-finding laser height sensor enables fast, non-contact dispense height measurement
- Digital vision system with enhanced vision software for superior imaging detection
- Patented CPJ process control automatically compensates for changes in fluid viscosity and higher yield.



Quantum Q-6800
Series Inline

Quantum Q-6800
Series Batch

Flexibility. The Quantum® Q-6800 Series offers uncompromising quality, speed, flexibility and value for batch and inline dispensing applications with mid- to higher-level complexity.

Advanced Process Control. The Quantum Series includes advanced process management features such as a fluid weight scale, patented Mass Flow Control (MFC)/Calibrated Process

Jetting™ (CPJ) closed-loop process control, range-finding laser height sensor, digital vision system with enhanced fiducial image processing, and programmable substrate heat capability.

Expert Value and Support. Our worldwide engineering, applications development and technical service network provide expert support from initial process development through full-scale production.

Quantum Q-6800 Series Features

ASYMTEK applicator technology and Quantum Series platform capabilities combine to deliver a reliable and cost-effective solution for PCBA, SMT and other demanding electronic assembly applications.

Recommended Applications

- CSP, BGA and board-level underfill
- Surface mount adhesives
- Corner and edge bonding
- Dam and fill
- Potting and encapsulation
- Conductive epoxy
- Case assembly
- Larger board or substrate sizes

Delivering Technology + Process Capability + Global Support

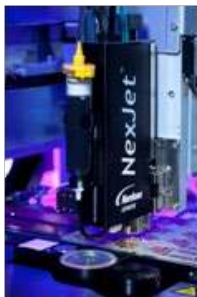

NexJet® 8
Jetting System

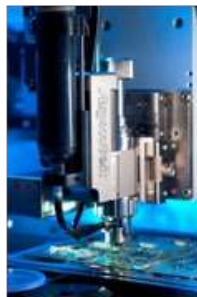

DispenseJet®



Heli-Flow® Pump

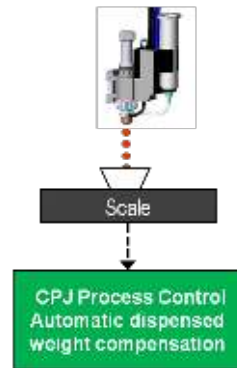

With an established reputation for quality, **ASYMTEK Applicators** offer flexibility and lower cost of ownership.



Digital Vision System incorporates an easy-to-use powerful vision algorithm to enable quick finding and teaching of fiducials even when targets vary in size, contrast or rotation.

Patented Mass Flow Control (MFC)/Calibrated Process Jetting (CPJ) ensure the right amount of material is dispensed for each part from the beginning to the end of the production run.



With DDC



Without DDC

Dynamic Dispense Control (DDC) provides precise control of the valve for more accurate placement of dots and lines.

Quantum Q-6800 Series Specification Highlights

Standard

- Range-finding Laser Height sensor
- Calibration Station
- Digital Vision system
- Weight Scale with CPJ/MFC
- Single applicator support

Available

- Dual applicator support
- Dual-lane configuration
- Fids-on-the-Fly™ software
- Pre- and post-queue stations
- SECS/GEM interface

Dispense Area (X-Y)¹

423 x 458 mm (16.7 x 18.0 in.), single applicator with offsets for vision and height sense; tooling size dependent

System Dimensions and Weight

System footprint: 1100 x 1241 mm (43.3 x 48.8 in.)

System weight²: 435-490 kg (960-1080 lbs.)

Standards Compliance

SEMI-S2; SEMI-S8; SMEMA; CE

Board Handling¹ (not applicable for Batch configuration)

Max. board/carrier length:

- One station: 600 mm (23.6 in.)
- Three stations: 320 mm (12.6 in.)

Min. board/carrier length: 25 mm (0.98 in.)

Max. board/carrier width:

- Single lane: 520 mm (20.4 in.)
- Dual lane: up to 220 mm (8.6 in.)

Min. board/carrier width: 25 mm (0.98 in.)

Max. board/carrier thickness: 12 mm (0.5 in.)

(1) Contact factory regarding other travel distance, board/carrier size compatibility

(2) System weight varies depending on configuration

Quantum Q-6800 Series Specification Highlights

Dimensions

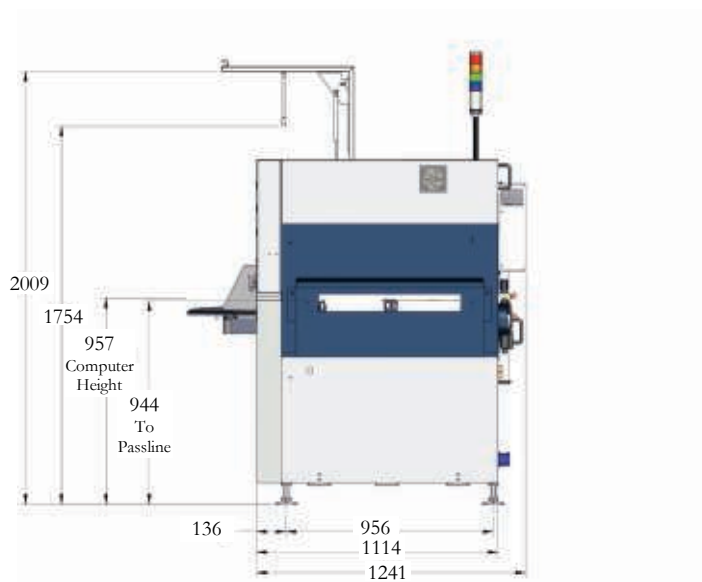

Side View (mm)

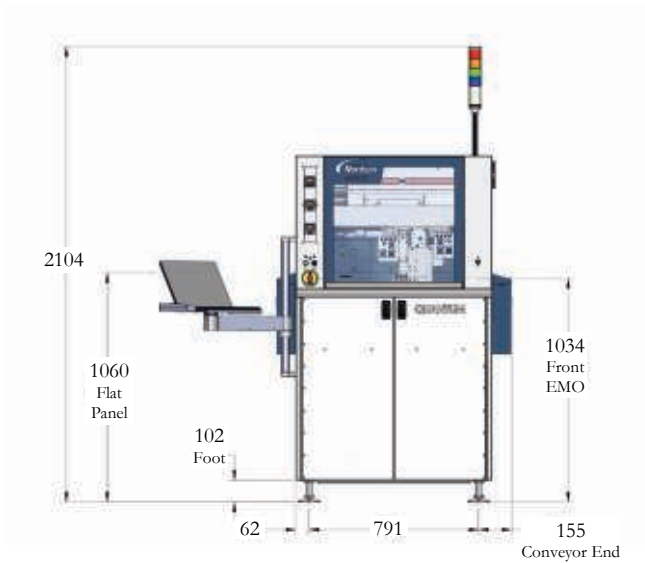

Front View (mm)

For more information, visit our website to find your local regional office or representative.

We have several global locations to serve you.

North America

Asia Pacific

EMEA

nordsonasymtek.com/global-locations

info@nordsonasymtek.com

North America Headquarters

2747 Loker Avenue West
Carlsbad, CA USA 92010-6603
+1.760.431.1919

Published August 2020